



Fracture Two-Tone Wall Panels

Premier Collection

Fracture Two-Tone is a double-layer acoustic wall panel precision cut to reveal the secondary base color. Various designs make up the 10 repeatable patterns that are entirely unique to Acoufelt.

Specifications

Surface	Wall
Material	FilaSorb™ polyester felt
Thickness	1/2", 14mm (±10%) 1", 26mm (±10%)
Weight	14mm, 0.49 lb./ft ² (±10%) 26mm, 0.98 lb./ft ² (±10%)
Standard Sizes	48" W x 108" H <i>Custom sizes available</i>



Fracture Two-Tone Wall Panel with Barcode Pattern in Platinum and Flamingo



Fracture Two-Tone Wall Panel with Shard Pattern in Pistachio and Wasabi

Technical

NRC Rating	14mm 0.55, no air gap 0.70, 20mm air gap 0.75, 50mm air gap 26mm product testing is in progress
Fire Test	ASTM E84, Class A Flame spread index: 15 Smoke developed index: 200
Water Sorption	ASTM C1104-2019 (A Modified) Water sorbed by weight: 0.20% (based on a 12mm thick panel)
Colorfastness	ISO 105-B02, 6-7

Details

Lead Time	3 – 6 weeks
Origin	Manufactured and assembled in the US
Warranty	Product: 20 years* Colorfastness: 20 years*

* Conditions apply

Environmental

Recycled Content	Minimum 60%
Energy	Generated using 40% solar energy
Indoor Air Quality	VOC less than/equal to 0.5mg/m3
Recyclable	100%*
Certifications	Declare Certification - LBC Red List Free (third-party verified) SCS Global Indoor Advantage Gold

* PET is recyclable through participating partners.



Colorways

PREMIER

							
White WH12	Almond AL55	Celery CE65	Sencha SE58	Metal ME03	Flamingo FL61	Quartz QU67	Turmeric TU60
							
Platinum PL04	Pearl PE21	Pistachio PI25	Thistle TH28	Stonewash ST72	Amethyst AM69	Valentine VA70	Wheat WH68
							
Grey GR02	Ivory IV11	Eucalyptus EU71	Peacock PE20	Periwinkle PE23	Lilac LI13	Peach PE19	Popcorn PO26
							
Slate SL27	Umber UM54	Wasabi WA29	Sea Salt SE57	Marine MA15	Berry BE06	Peppercorn PE22	Carrot CA08
							
Charcoal CH01	Walnut WA56	Oregano OR18	Azure AZ05	Iris IR10	Flint FL64	Shiraz SH63	Currant CU59
							
Piano Black PI24	Midnight MI16	Kale KA12	Denim DE09	Granite GR62			

Order samples at acoufelt.com/colorways



Call 800.966.8557 with questions or visit acoufelt.com for more product information, downloads, and colorways.

Sizes

Standard Sizes	48" W x 108" H <i>Custom sizes available</i>
Thickness	1/2", 14mm (±10%) 1", 26mm (±10%)

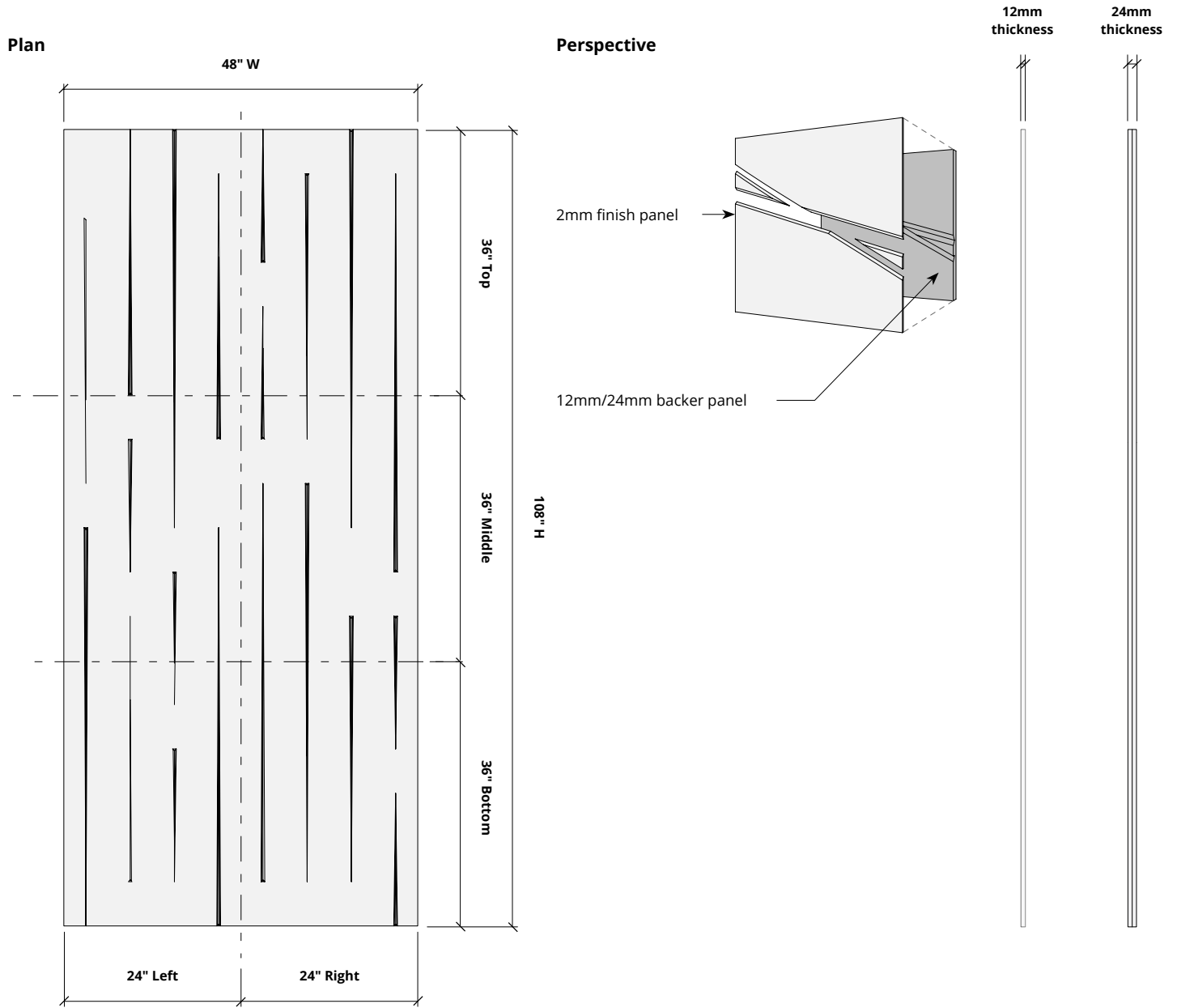

* Product available as full panels or as sections of a panel as filler pieces.
Choose any of the standard height or segments (i.e. bottom right, middle left, etc) to fill the space as needed.

How to Specify

1. Choose Panel Pattern

2. Choose Colorways

Select desired panel pattern. See recommended layouts for larger designs.

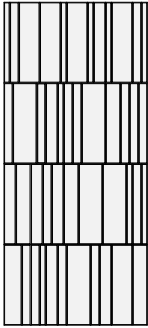

BARCODE



DASH

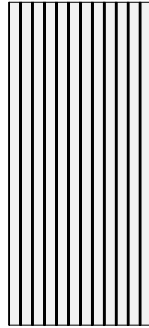

FINELINE

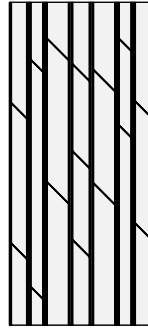

OPTICS

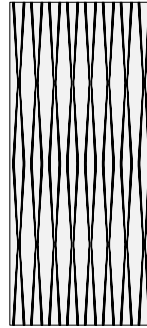

PARALLAX

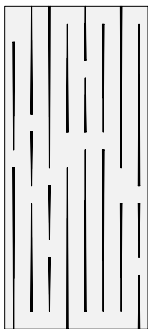

RAINDROP

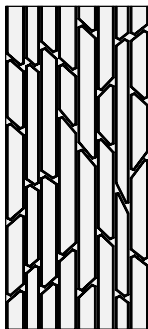

SHARD

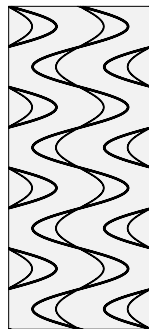

SMOKE

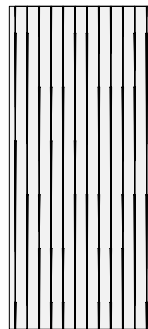

THREAD

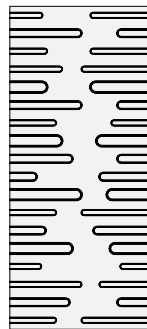

VAPOR

1. Choose Panel Pattern

2. Choose Colorways

Select two colors: one for the face panel and one for the back panel to create a Fracture Two-Tone that is uniquely yours. See colorways on page 3.

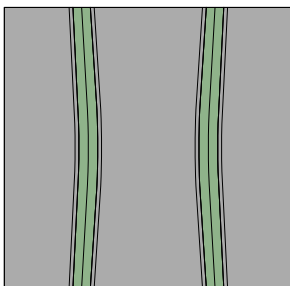

Parallax in Metal and Sencha



Recommended Layouts

Barcode

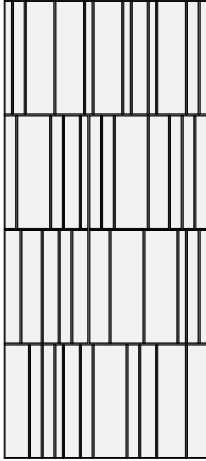

Layout 1

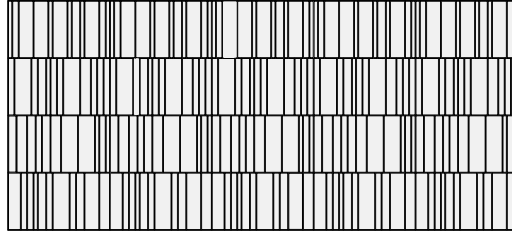

Layout 2

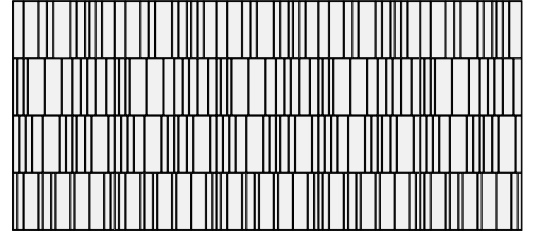

Layout 3

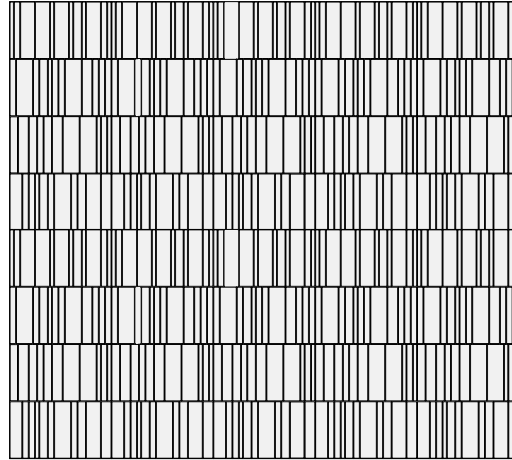

Layout 4

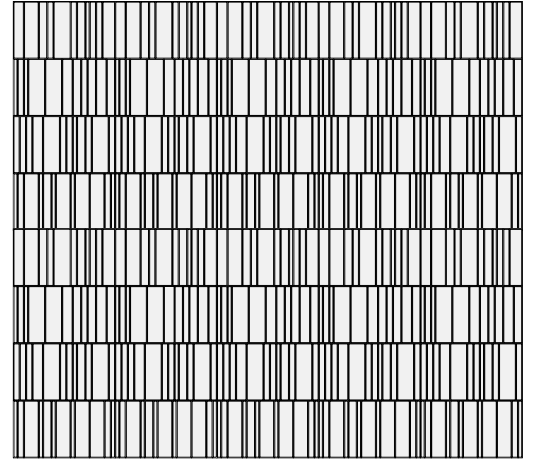

Perspective

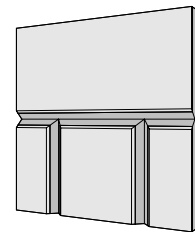

Recommended Layouts

Dash



Layout 1

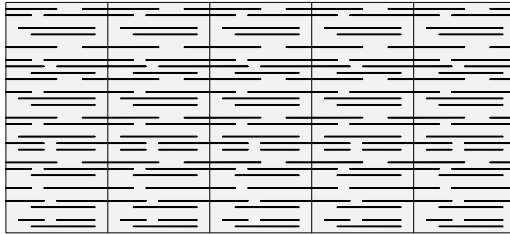

Layout 2

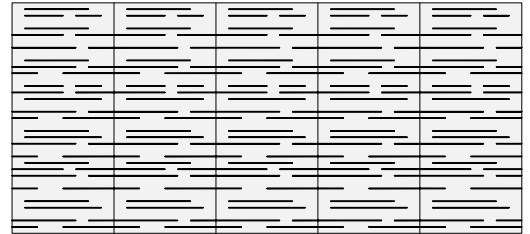

Layout 3

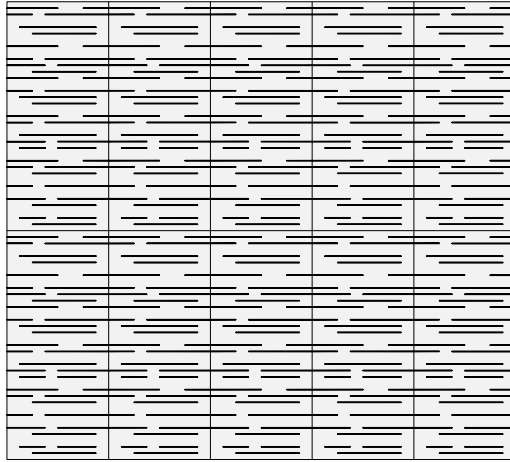

Layout 4

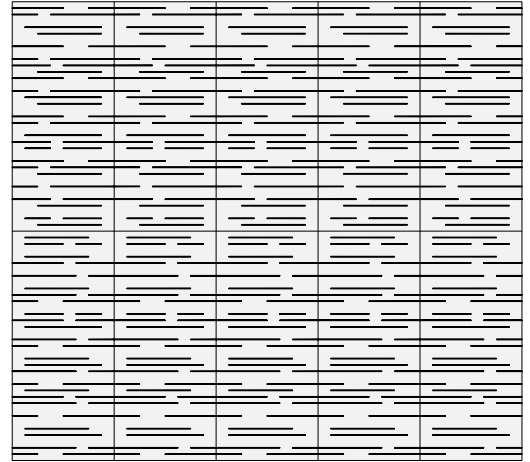

Perspective

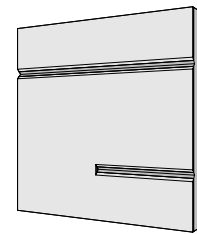

Recommended Layouts

Fineline

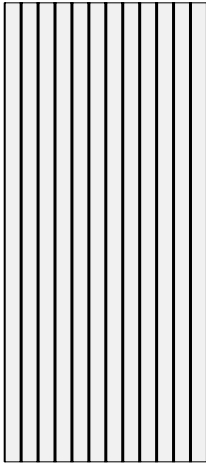

Layout 1

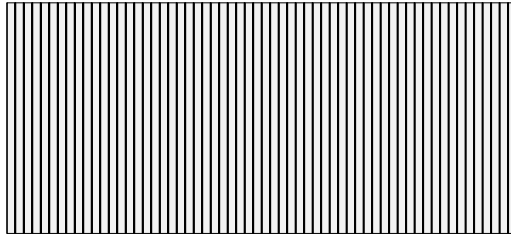

Layout 2

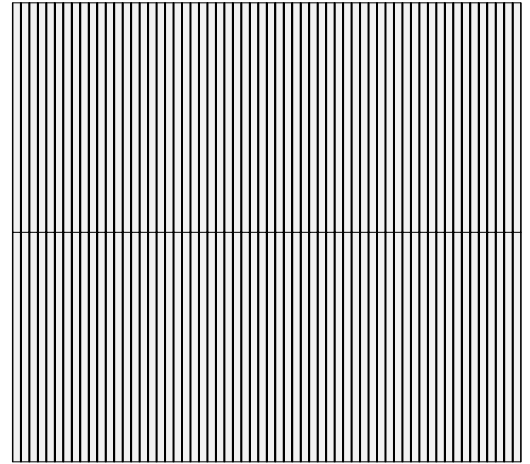

Perspective

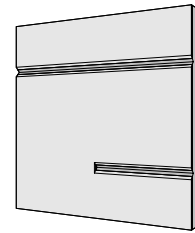

Recommended Layouts

Optics

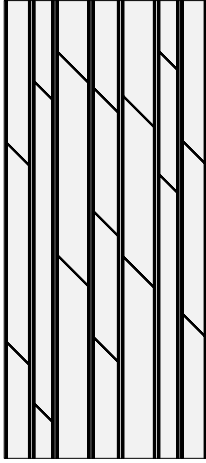

Layout 1

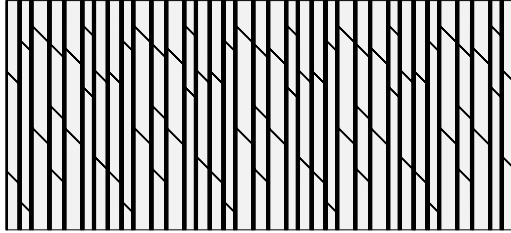

Layout 2

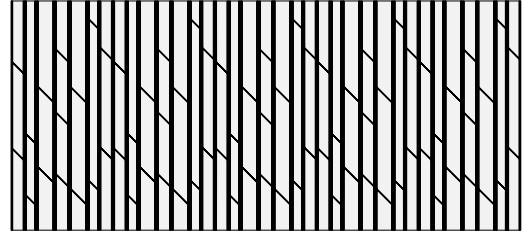

Layout 3

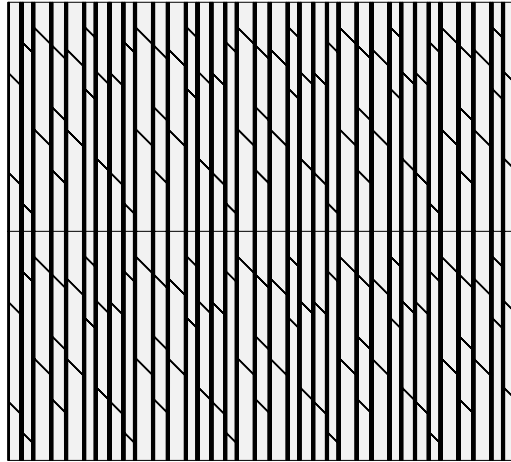

Layout 4

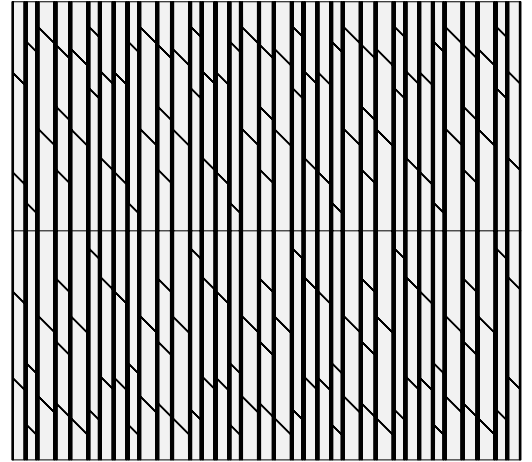

Perspective

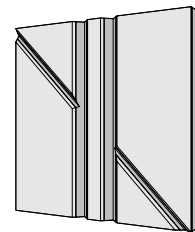

Recommended Layouts

Parallax

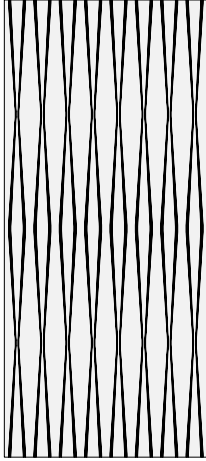

Layout 1

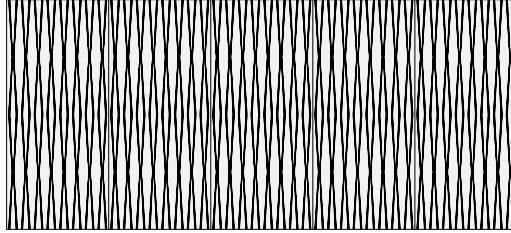

Layout 2

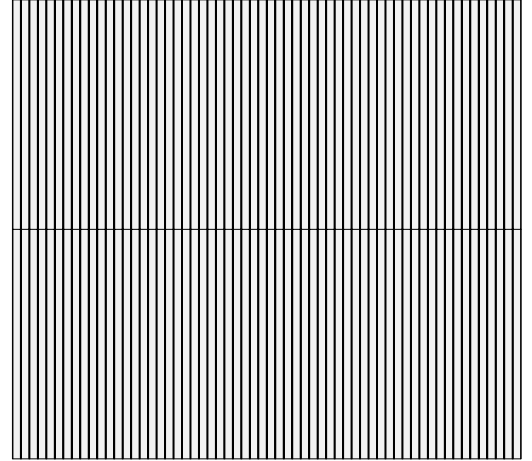

Perspective

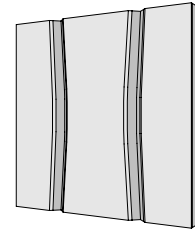

Recommended Layouts

Raindrop

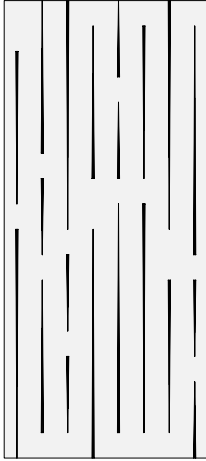

Layout 1

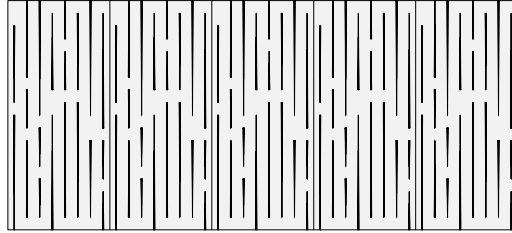

Layout 2

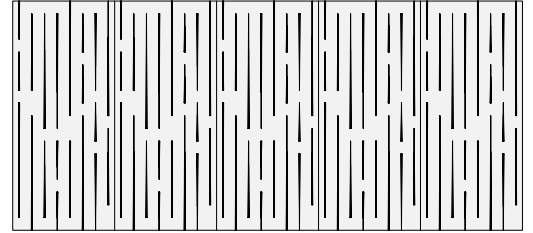

Layout 3

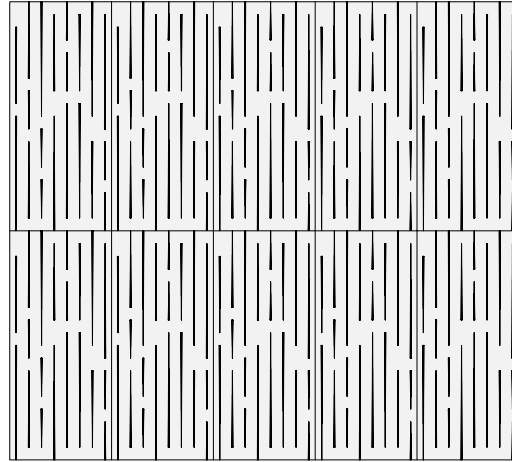

Layout 4

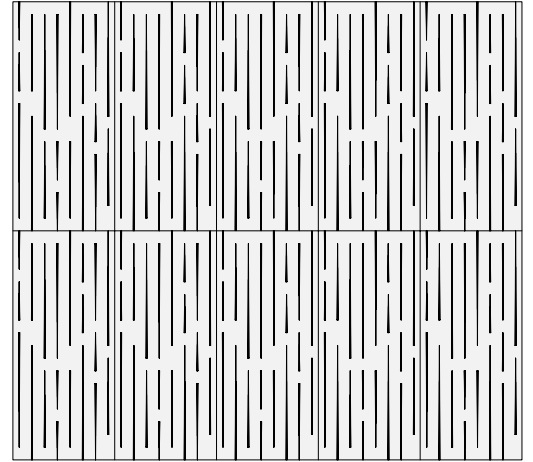

Perspective

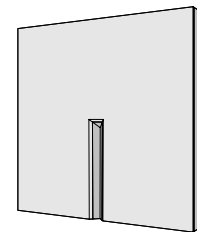

Recommended Layouts

Shard

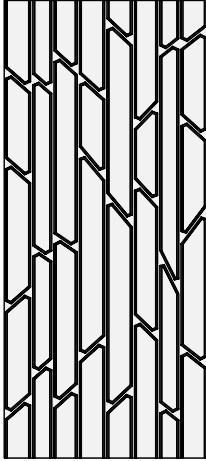

Layout 1

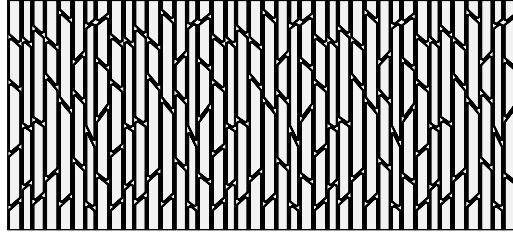

Layout 2

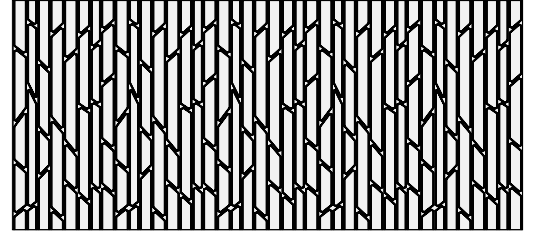

Layout 3

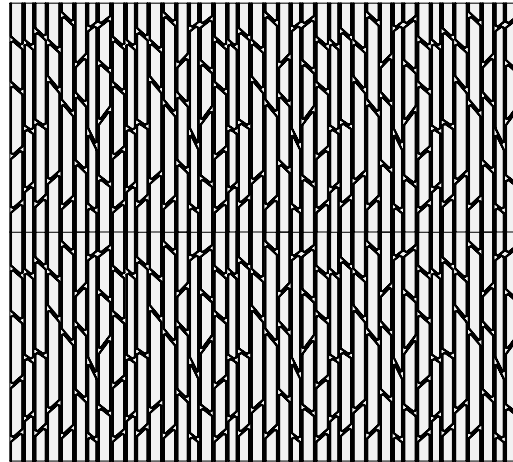

Layout 4

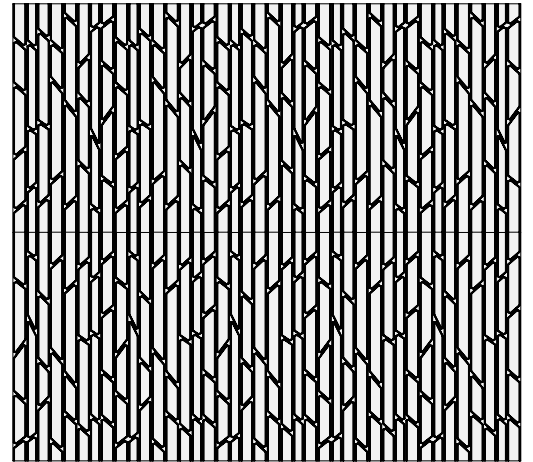

Perspective

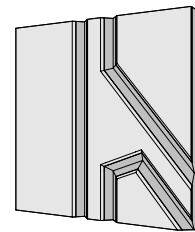

Recommended Layouts

Smoke

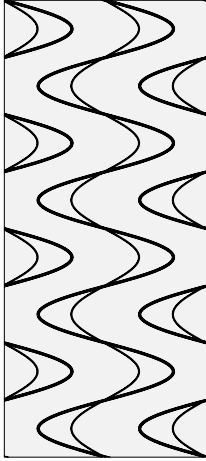

Layout 1

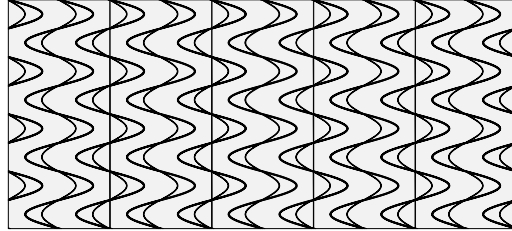

Layout 2

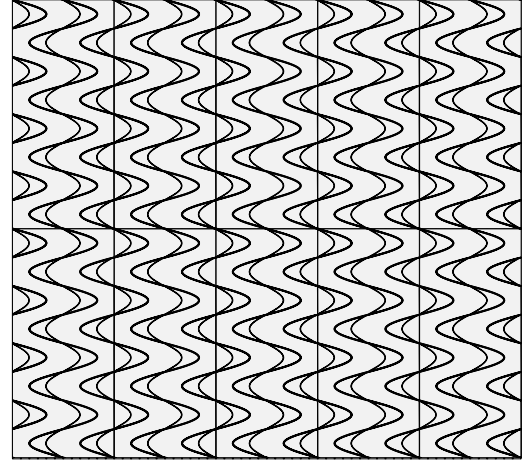

Perspective

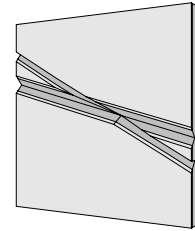

Recommended Layouts

Thread

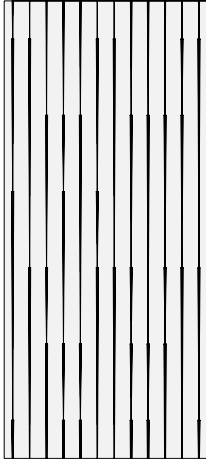

Layout 1

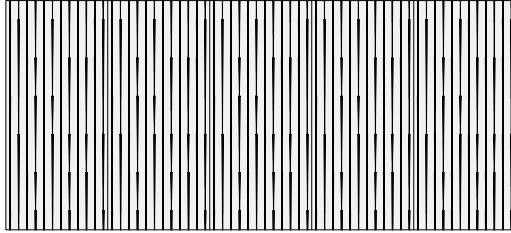

Layout 2

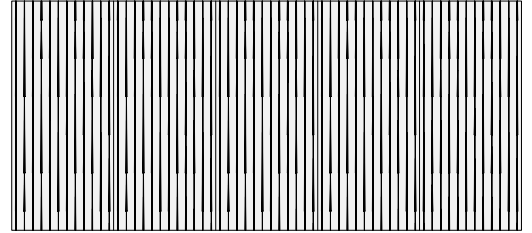

Layout 3

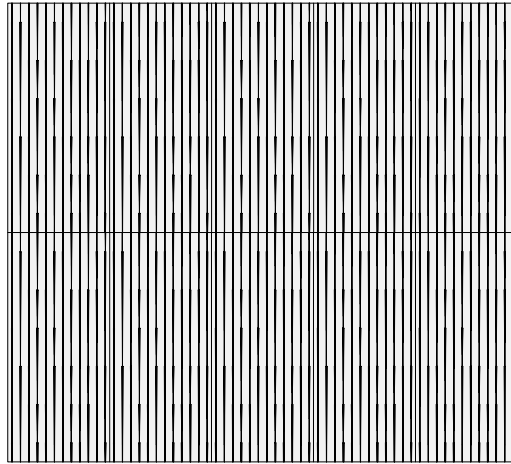

Layout 4

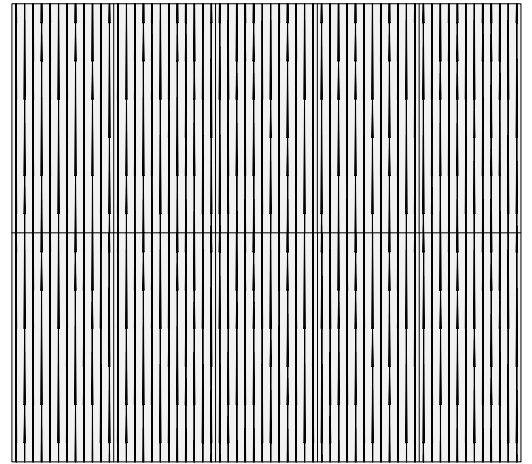

Perspective

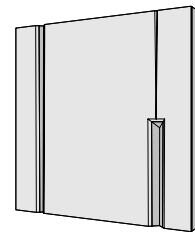

Recommended Layouts

Vapor

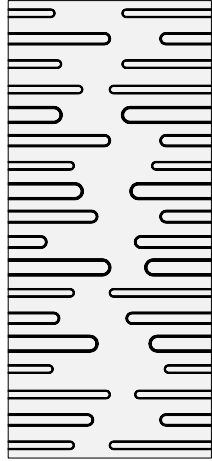

Layout 1

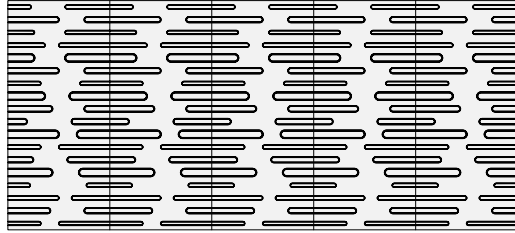

Layout 2

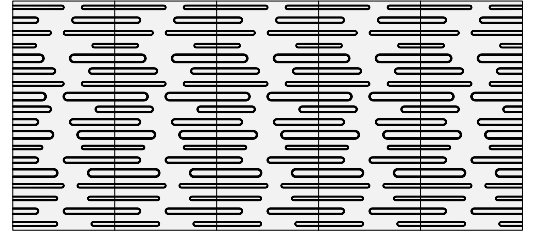

Layout 3

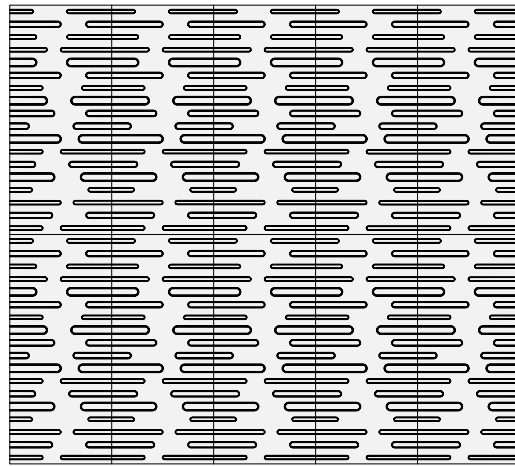

Layout 4

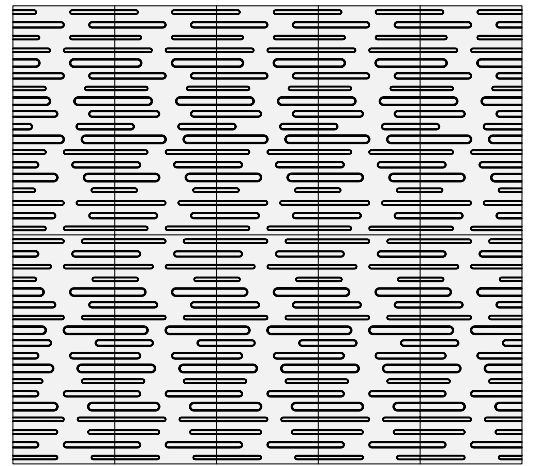

Perspective

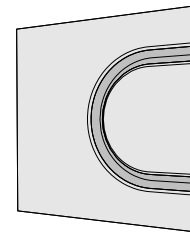

Mounting Methods

Adhesive backing

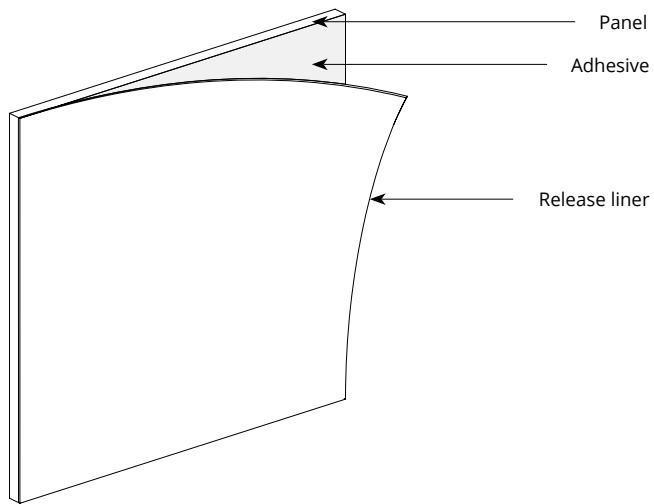

Construction adhesive

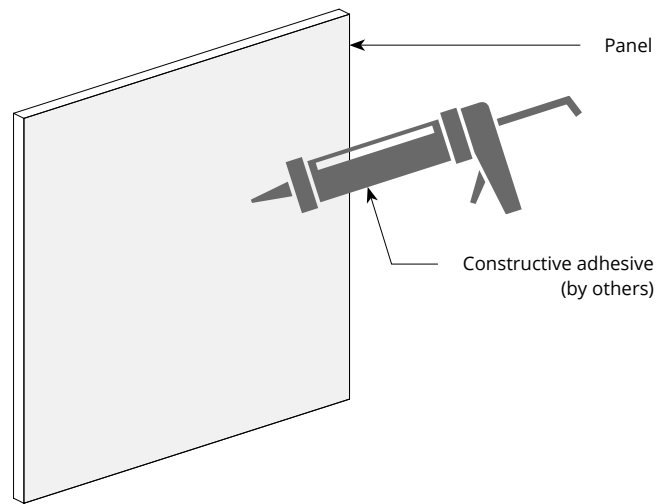

Z-clip wall mount

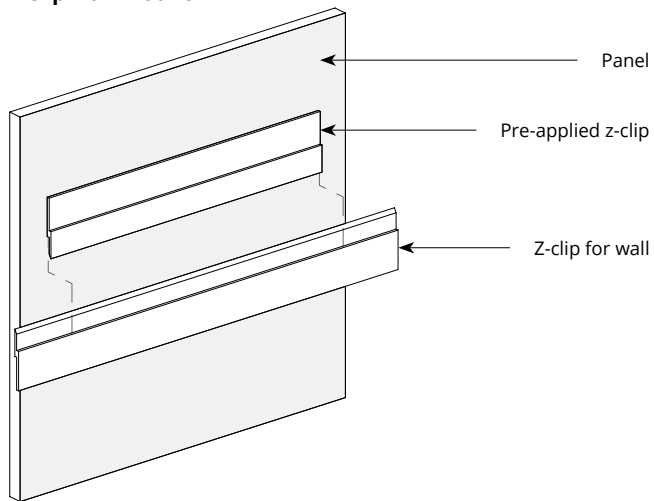

* For wall mount applications only.

Acoustic Performance

Test Method	ASTM 354-2006
Install Method	A
Rating Method	ISO 11654-2002
Test Results	<p>14mm NRC 0.55 NRC 0.70, 20mm air gap NRC 0.75, 50mm air gap SAA 0.56, no air gap SAA 0.70, 20mm air gap SAA 0.76 50mm air gap</p> <p>26mm Product testing is in progress</p>

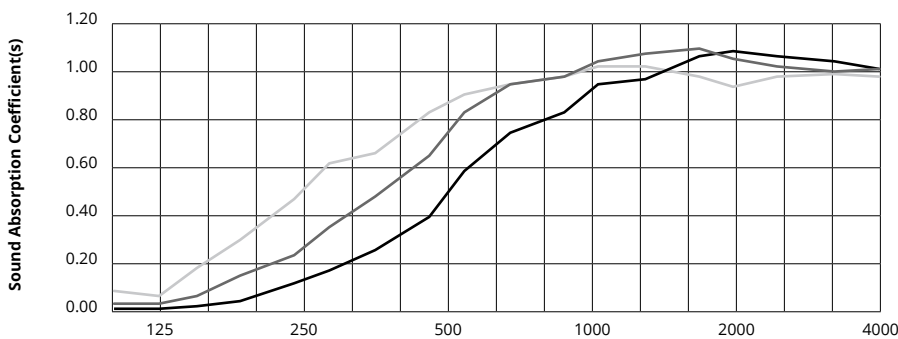

	Frequency f (Hz)	125	250	500	1000	2000	4000	NRC
	14mm	0.01	0.11	0.37	0.78	1.00	0.98	0.55
	14mm, 20mm air gap	0.03	0.22	0.61	0.93	1.03	0.94	0.70
	14mm, 50mm air gap	0.06	0.44	0.78	0.92	0.92	0.93	0.75
	26mm	Product testing is in progress						

What is a Noise Reduction Coefficient (NRC)?

You'll find the NRC rating in the specifications of all of our products. This acronym stands for Noise Reduction Coefficient, and is expressed as a single number, a rating that describes the degree to which acoustic products can absorb sound.

You can use NRC values to understand the overall performance of our acoustic wall and ceiling products. The higher the NRC, the better the product is at soaking up the sound.

Performance Indices: Noise Reduction Coefficient (NRC) results represent the absorption coefficients measured at the one third octave bands at 125, 250, 500, 1000, 2000 and 4000 Hz rounded to the nearest 0.05. Acoustic testing has been performed according to the methods mentioned above. Customization of installation of the product could alter the results. Sound Absorption Average (SAA) indicates the absorption coefficient average for the twelve one-third octave bands ranging between 200 and 2500 Hz.